

SERGE BARIL GTCK GUT TRACE CONNECTION KIT FOR TYPE FPS-BT & IN-PIPE HEATER CABLE

INSTALLATION INSTRUCTIONS

Description:

The GTCK Gut Trace Connection Kit includes the power connection and end seals. It is for use with FPS-BT & IN-PIPE type heater cables.

Kit Contents:

- | | |
|-----------------------|--------------------------------|
| 1 Compression Fitting | 3 Shrink Tube, 19mm (.75") ID |
| 1 Compression Cap | 1 Shrink Tube, 12mm (.5") ID |
| 3 Butt Splices | 2 Shrink Tubes, 3mm (.125") ID |
| 1 Grommet | 1 Bushing, 19mm (.75") |
| 1 Pull Cord, nylon | |

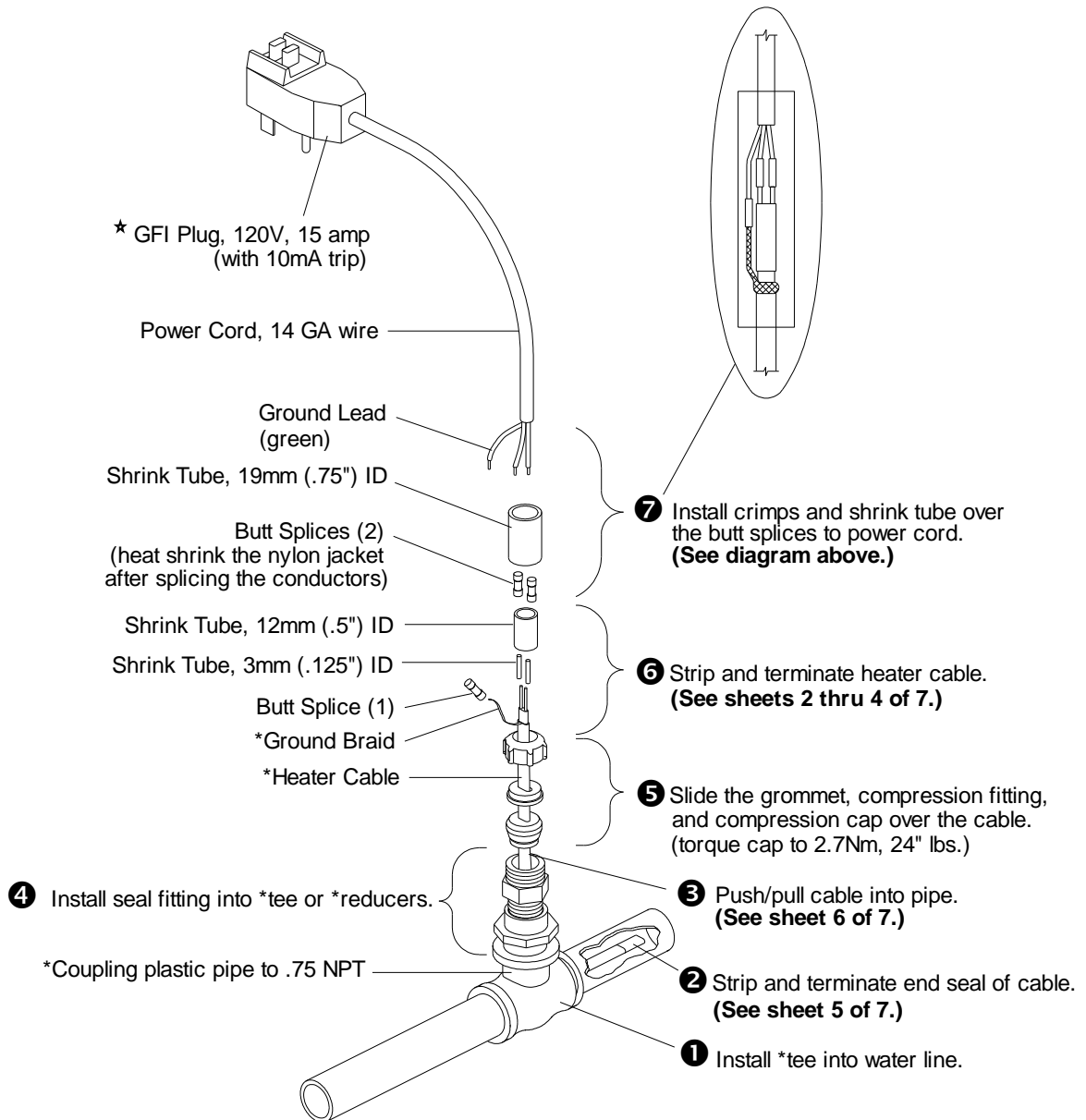

***ITEMS NOT INCLUDED IN KIT**



OVERJACKET PRODUCTS

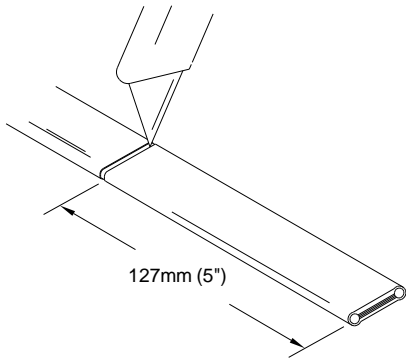

! WARNING:
DO NOT CUT BRAID

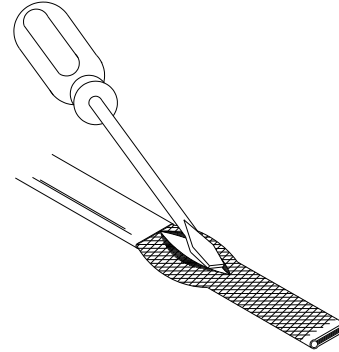

- 1** Lightly cut around heater overjacket 127mm (5") from the end. Bend cable to break the overjacket.
- 2** Lightly cut overjacket up the center between first cut mark and the cable end. Bend cable to break the overjacket.

- 5** At the bulge, separate the braid to make an opening.

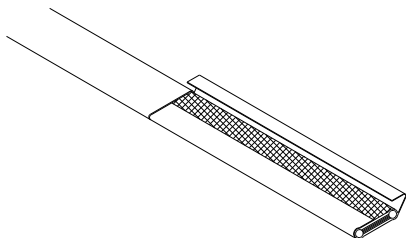
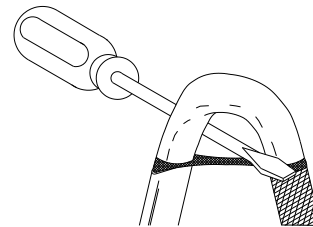

- 6** While bending the heater cable, work it through the braid opening.

- 3** Remove overjacket from heater cable.

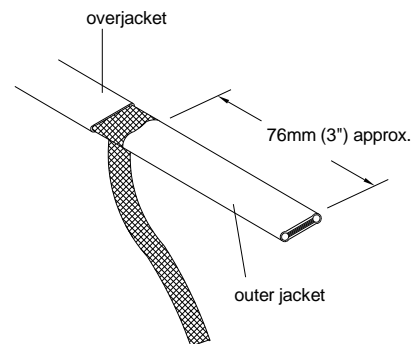
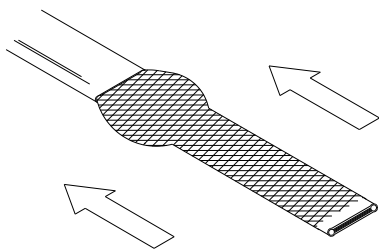

- 4** Move braid back toward the overjacket, creating a bulge.

- 7** Pull the braid tight.

- 8** Proceed to "Stripping Instructions", sheet 3 of 7.

STRIPPING INSTRUCTIONS

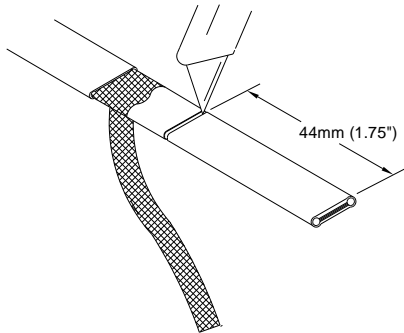

- 1 Lightly cut around heater jacket 44mm (1.75") from the end of cable. Bend cable to break jacket.
- 2 Lightly cut the jacket up the center between the first cut mark and the end of cable. Bend cable to break jacket.

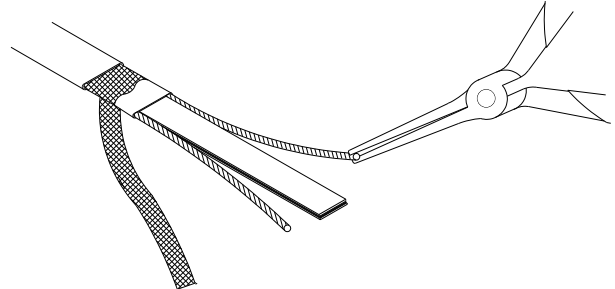

- 5 Starting at the end, pull each bus wire away from the core.
- 6 Remove exposed core material.

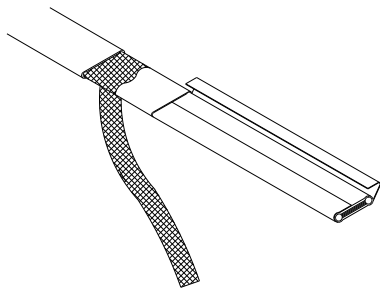

- 3 Remove the jacket from the heater cable.

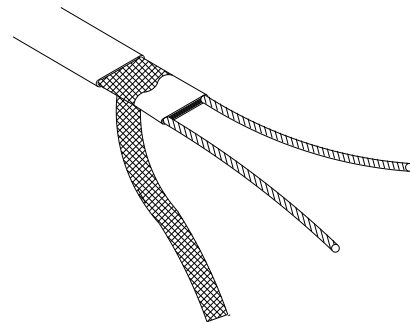

- 7 Cut 6mm (.25") off the end of each bus wire before installing the power termination.
- 8 Proceed to "Power Feed End Termination", sheet 4 of 7.

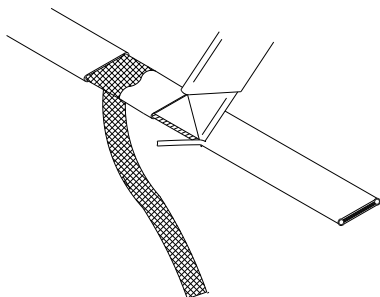

- 4 Shave the core material from the outside of each bus wire.

⚠ WARNING:
DO NOT CUT BUS WIRES

SERGE BARIL GTCK GUT TRACE CONNECTION KIT FOR TYPE FPS-BT & IN-PIPE HEATER CABLE

INSTALLATION INSTRUCTIONS

POWER FEED END TERMINATION

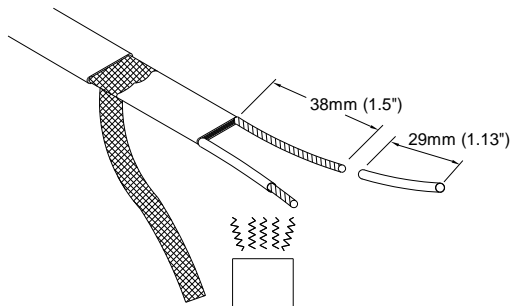

- 1 Slide a 3mm (.125") ID shrink tube over each bare bus wire and shrink with an industrial heat gun or rapidly moving fluffy flame.

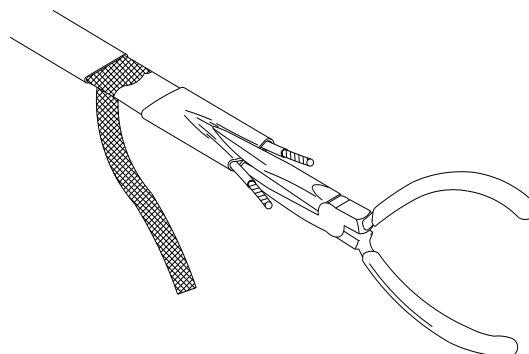

- 3 While still warm, spread pigtail wires and squeeze with needle-nose pliers.

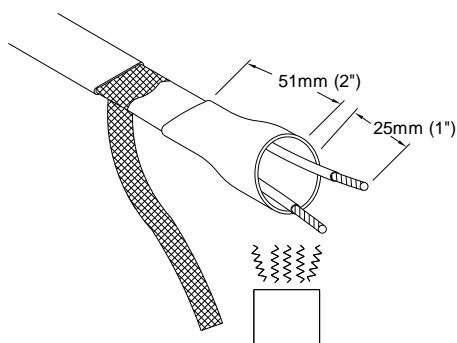

- 2 Slide the 12mm (0.5") ID shrink tube over both wires, 25mm (1") of each bus wire should be exposed. Shrink with an industrial heat gun or rapidly moving fluffy flame until completely shrunk.

END SEAL FOR INTERNAL TRACE APPLICATION

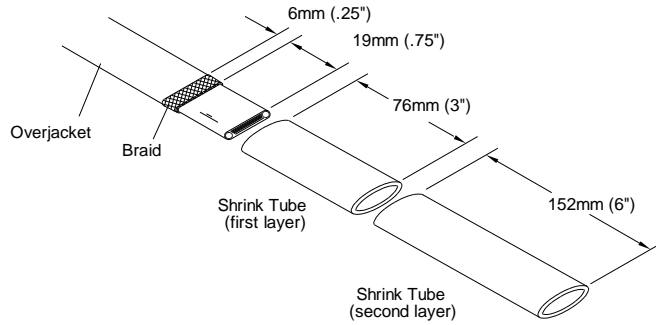

- 1 Remove 19mm (.75") of overjacket.
- 2 Trim braid and push back over the overjacket.

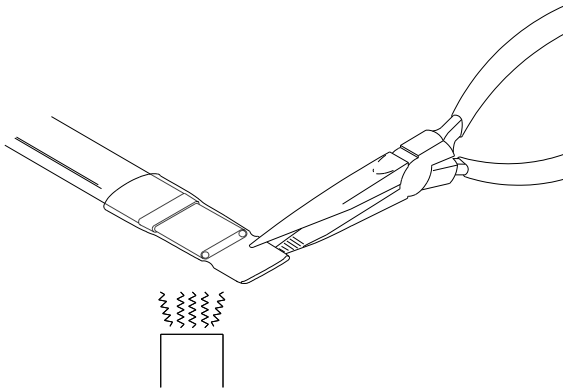

- 3 Place the first layer of shrink tube over the end seal and shrink with an industrial heat gun or rapidly moving fluffy flame. Allow approx. 19mm (.75") of shrink tube to extend past the end seal.
- 4 Use needle-nose pliers to seal the shrink tube at the end as shown.

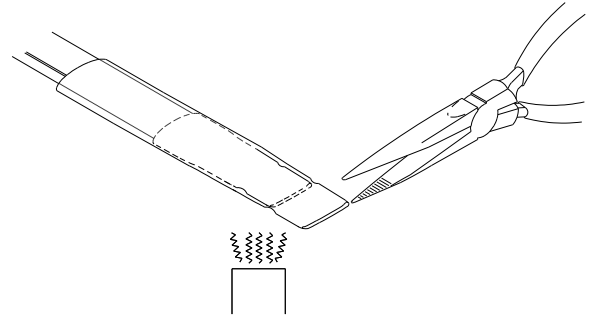

- 5 Place the second layer of shrink tube over the end seal and shrink with an industrial heat gun or rapidly moving fluffy flame. Allow approx. 25mm (1") of shrink tube to extend past the end seal.
- 6 Use needle-nose pliers to seal the shrink tube at the end as shown.

PULL CORD INSTALLATION

Typically used on cable lengths in excess of 15m (49')

The short cable lengths will not require any pulling methods for the heater cable installation. Longer cable lengths may require a pipe tee or several tees to be installed along the pipe route to allow the use of a fish tape or rope for pulling the heater cable.

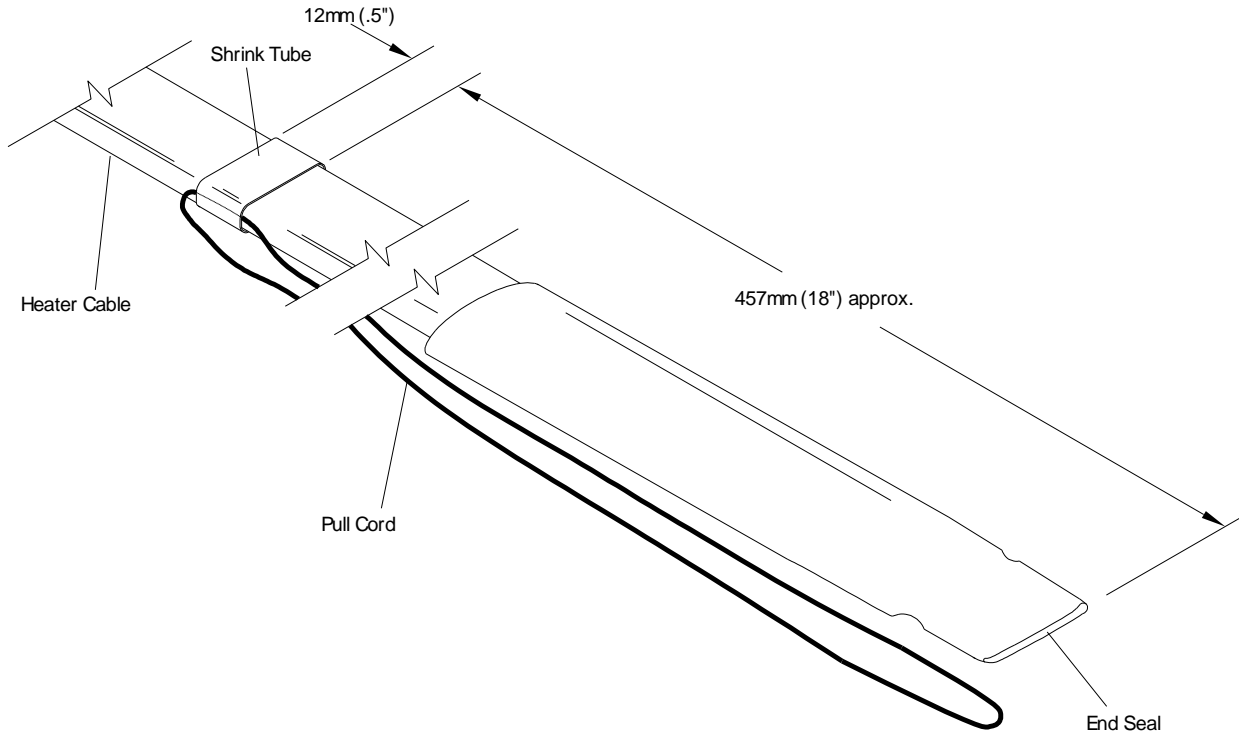

- 1 Install the nylon pull cord through the shrink tube and tie the ends together. (The pull cord length should be approx. 2m (6.6') long.)
- 2 Slide the shrink tube as shown and shrink with heat gun. (Make sure the cord moves freely for easy removal later.)
- 3 After the heater cable is installed, cut & remove the pull cord.

⚠ WARNINGS:

- DO NOT PULL ON THE END SEAL DURING THE INSTALLATION PROCESS.
- ELECTRICAL SHOCK MAY RESULT FROM DAMAGED END SEAL.

**SERGE BARIL GTCK
GUT TRACE CONNECTION KIT
FOR TYPE FPS-BT & IN-PIPE HEATER CABLE**

**INSTALLATION
INSTRUCTIONS**

GUT TRACE APPLICATION

Standard Line Application:

Heater Catalog #: IN-PIPE
Operating Voltage: 120VAC
Power Output at 0°C (32°F): 8.5 W/m (2.6 W/ft.)
Maximum Circuit Length: 77m (252')

Start-Up Data	-60°F	-40°F	-20°F	0°F	+20°F	+50°F
Amps / m	0.269	0.246	0.220	0.194	0.171	0.131
Amps / ft.	0.082	0.075	0.067	0.059	0.052	0.040
Max. Length - 15 Amp Breaker	184	200	225	252	252	252

The cable sets to be inside non-metallic pipes are for pressure, drain, waste and vent pipes. See the appropriate CSA Standard number for the different types of plastic pipe:

Type of Plastic Pipe	CSA Standard
LDPE	CAN / CSA-B137.1
HDPE	CAN / CSA-B137.1
PVC	CAN / CSA-B137-3
CPVC	CAN / CSA-B137.6
ABS (non-pressure)	CAN CSA-B181-1
FRP	No Standard

We are pleased to offer suggestions on the use of our various products, nevertheless, there are no warranties given except such expressed warranties offered in connection with the sale of a particular product. There are no implied warranties of merchantability or of fitness for a particular purpose given in connection with the sale of any goods. In no event shall Serge Baril be liable for consequential, incidental or special damages. The Buyer's sole and exclusive remedy and the limit of Serge Baril's liability for any loss whatsoever shall not exceed the purchase price paid by the Purchaser for the product or products to which a claim is made.

SERGE BARIL & ASS. INC.

5310 des Laurentides Blvd., Laval, (Quebec) Canada H7K 2J8
Tel: (450) 622-7587 Fax: (450) 622-7869

