

GRK-E END SEAL SHRINK TUBE

DESCRIPTION

The GRK-E is for use with Serge Baril FPS and CCA heater cables.

KIT CONTENTS

GRK-E-5

- 5 Heat shrink tubes, 51mm (2") length
- 5 Heat shrink tubes, 76mm (3") length

GRK-E-1

- 1 Heat shrink tube, 51mm (2") length
- 1 Heat shrink tube, 76mm (3") length

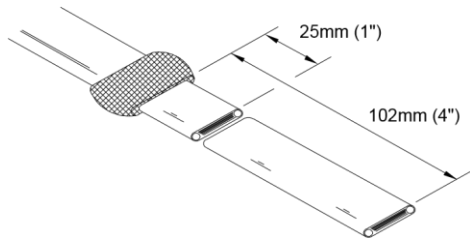

- 1 Cut heater cable off at required length. Strip overjacket back 102mm (4") from the end of heater cable. Slide braid back over the overjacket portion of the heater cable. Cut off excess heater cable leaving 25mm (1").

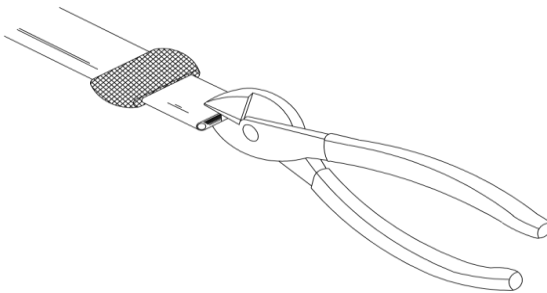

- 2 At the end of the heater cable, snip a 9.5mm (.375") slit between the bus wires. Slightly spread wires apart.

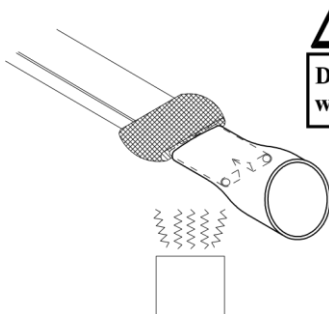

WARNING:
Do not overlap braid with shrink tube.

- 3 Slide a 51mm (2") length shrink tube over the heater cable leaving 25mm (1") of shrink tube past the heater cable. Shrink with heat gun until completely shrunk.

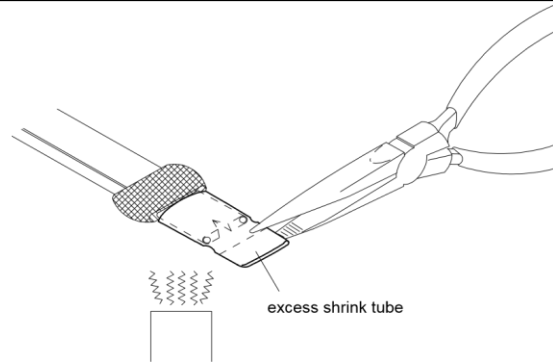

- 4 While still warm, squeeze the entire width of shrink tube closed. Cut off excess shrink tube.
- 5 Pull braid over the squeezed shrink tube, covering the entire end seal.

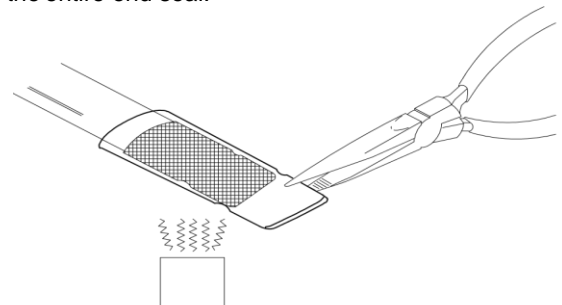

- 6 Slide a 76mm (3") length shrink tube over the braid leaving 12mm (0.5") of shrink tube past the braid. Shrink with heat gun until completely shrunk. While still warm, squeeze the entire width of shrink tube closed.

SERGE BARIL & ASS. INC.

5310 des Laurentides Blvd., Laval, QC Canada H7K 2J8
Tel: (450) 622-7587 Fax: (450) 622-7869
Web: baril.ca E-mail: serge@baril.ca

