

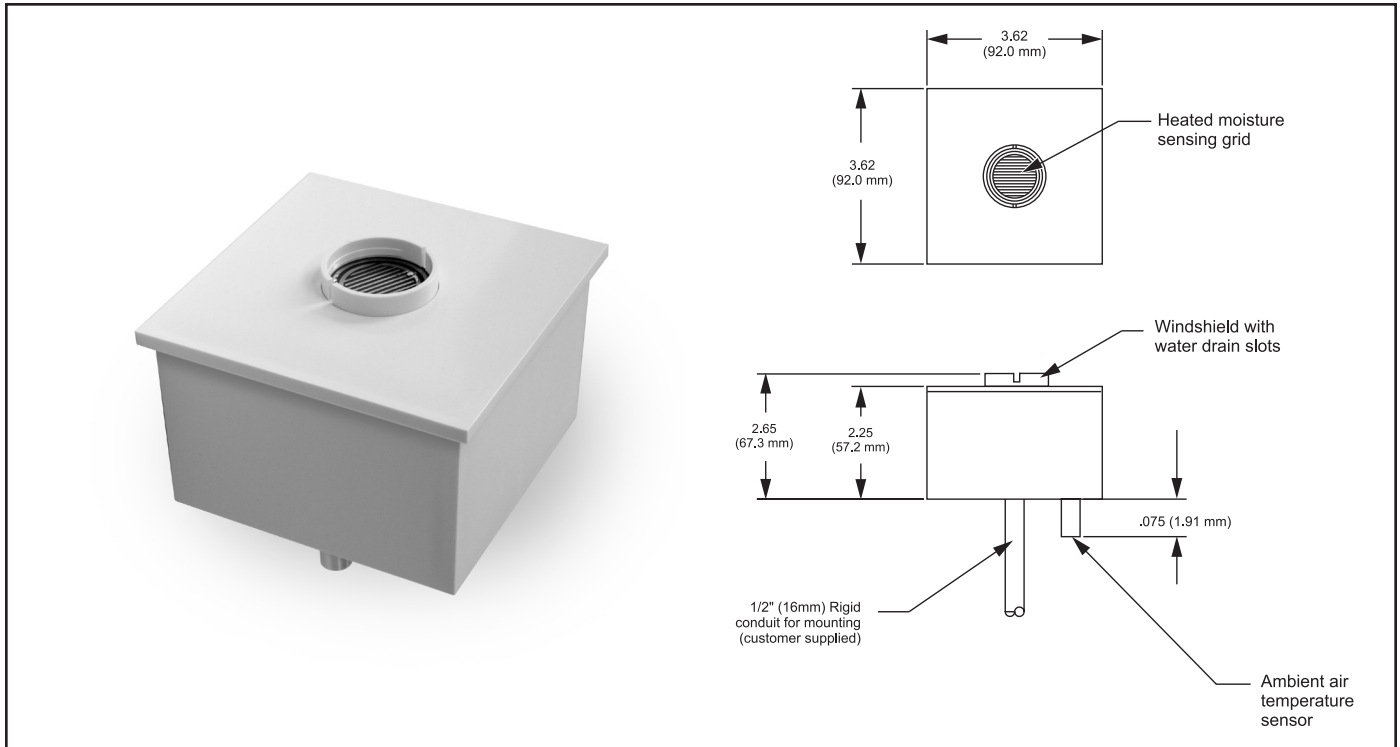

We Manage Heat®

### FEATURES & BENEFITS

- Low cost
- Reliable automatic control
- U-L Listed/CSA Certified
- Simple installation
- Field proven in thousands of installations
- Minimum snow melting costs
- No supervision required
- Designed and Assembled in the USA



### DESCRIPTION

The LCD-1 Snow Switch is an energy saving alternative to thermostat, manual or timer controls. Its low price ideally suits the LCD-1 for cost-sensitive residential and commercial snow melting applications.

Unlike thermostats, the LCD-1 Snow Switch operates heaters when precipitation occurs at temperatures below 38°F (3.3°C) and remains closed for a 5 hour hold-on time after

precipitation stops to ensure complete ice/snow melting. This saves substantial energy compared to other control techniques.

The LCD-1 Snow Switch operates from 120 VAC, 50/60 Hz. An integral relay rated for 120/240 VAC, 16 amp loads permits direct heater control for small applications such as wheelchair ramps and stairways or may operate external contactors in large installations.

Extensive quality control, high grade components and microprocessor technology contribute to trouble-free operation. These innovative field proven products provide reliable automatic control in thousands of installations.

For complete information describing its application, installation and features, please contact Customer Service or check on the web at [www.networketi.com](http://www.networketi.com).

## INSTALLATION

The LCD-1 housing has one 1/2" (16mm) NPT threaded opening. Choose an elevated location exposed to snow fall.

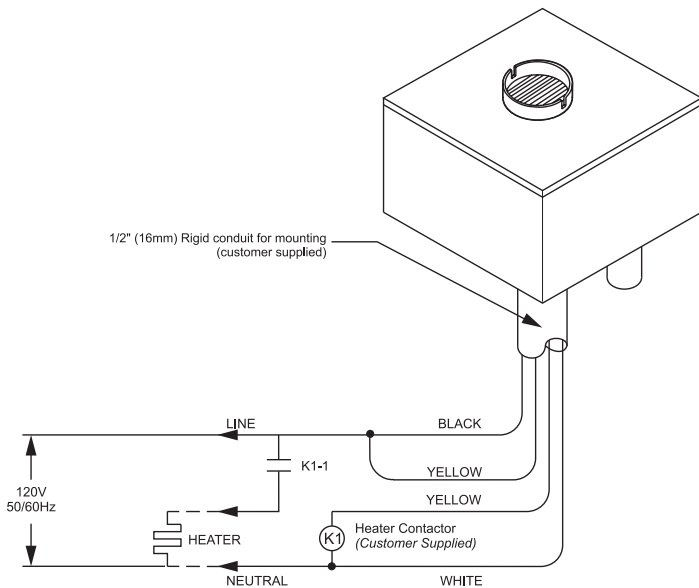

**Load Greater Than 16 Amps**

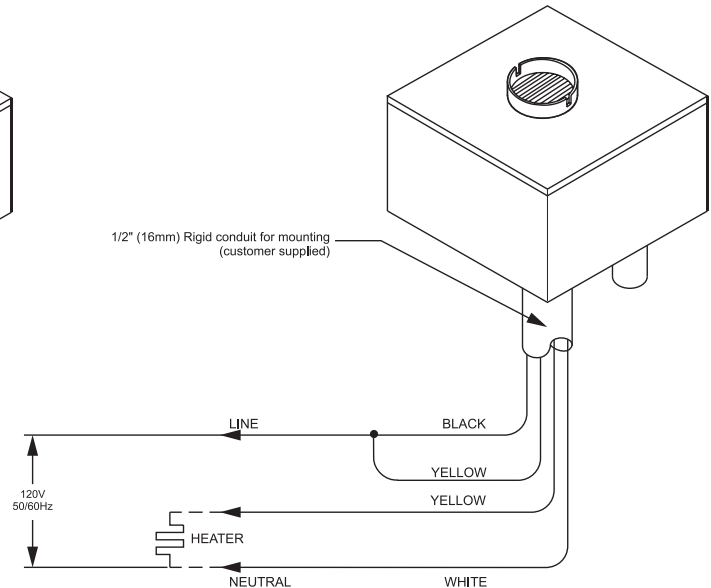

**Load Less Than and Up To 16 Amps**

## ORDERING INFORMATION

Order Number	Description
15898	LCD-1 Snow Switch (U-L Listed)

## LIMITED WARRANTY

ETI's two year limited warranty covering defects in workmanship and materials applies. Contact Customer Service for complete warranty information.

## DISCLAIMER

Environmental Technology, Inc. makes no representations or warranties, either expressed or implied, with respect to the contents of this publication or the products that it describes, and **specifically disclaims any implied warranties of merchantability or fitness for any particular purpose.** Environmental Technology, Inc. reserves the right to revise this publication, and to make changes and improvements to the products described in this publication, without the obligation of Environmental Technology, Inc. to notify any person or organization of such revisions, changes or improvements.