

SERGE BARIL HA-T HAZARDOUS AREA SEAL KIT

INSTALLATION INSTRUCTIONS

DIVISION 1 CABLE TEE SPlice TERMINATION & EXPLOSION PROOF SEAL

DESCRIPTION

The HA-T Hazardous Area Seal Kit provides the cable termination and explosion proof seal parts needed to make all electrical tee splice connections associated with Serge Baril's self-regulating heater cables.

KIT CONTENTS

1	Junction Box	3	Male Adapters
1	Box Cover Gasket	3	Reducer Bushings
1	Tube of Silicone	3	Power Terminations
1	Sealing Compound	1	Terminal Block
1	X Fiber	3	Cable Entry Seals
2	Pipe Clamps	3	Seal Fittings

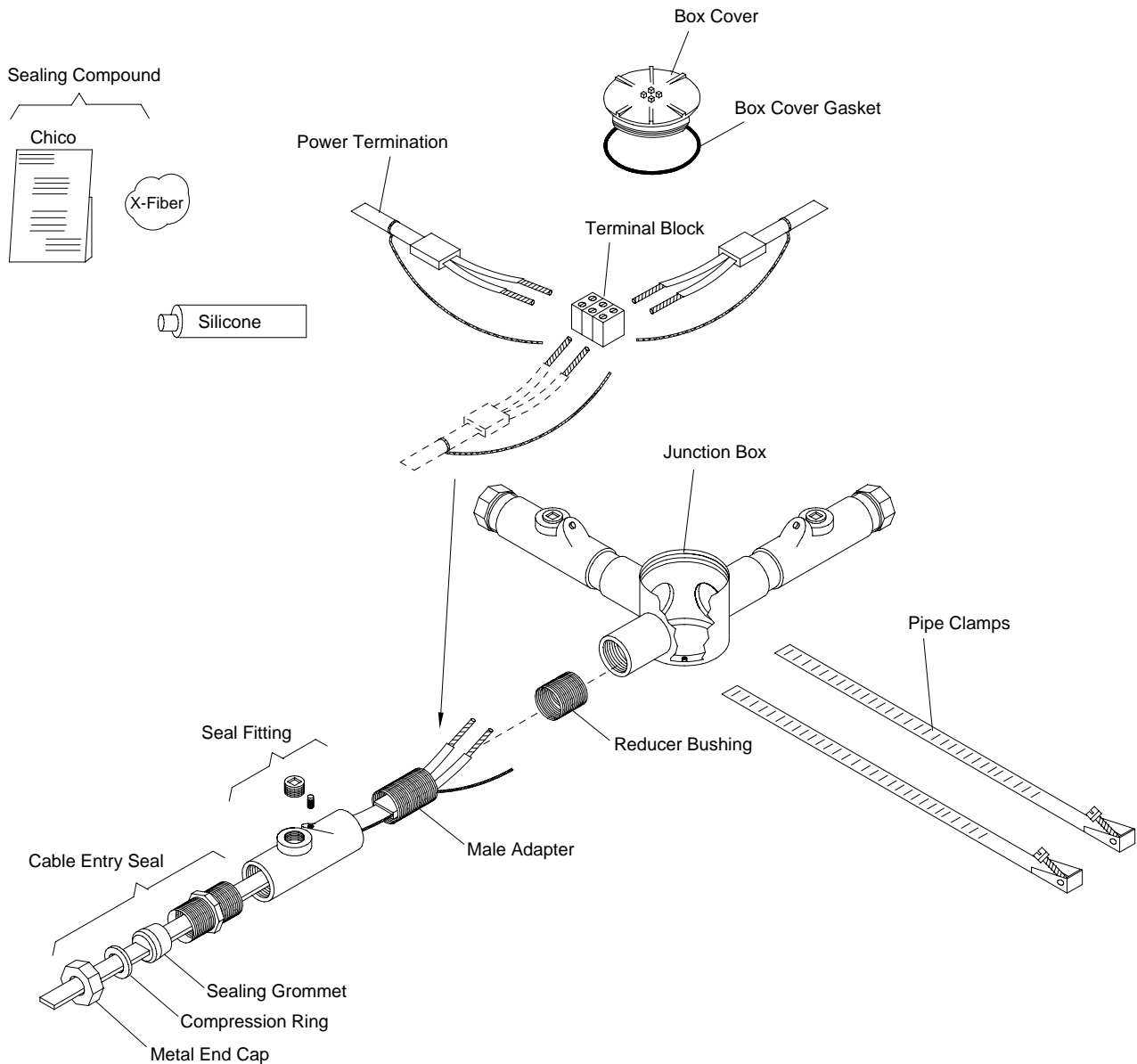

SERGE BARIL HA-T HAZARDOUS AREA SEAL KIT

DIVISION 1 CABLE TEE SPLICE TERMINATION & EXPLOSION PROOF SEAL INSTRUCTIONS

INSTALLATION INSTRUCTIONS

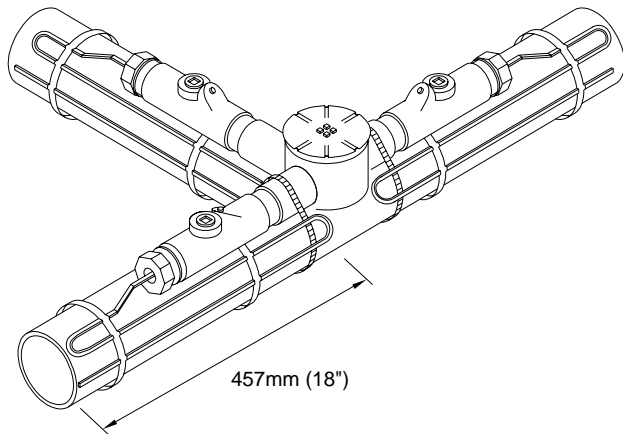

- 1 Allow 457mm (18") of heater cable for each side to compensate for heat loss of the termination kit.

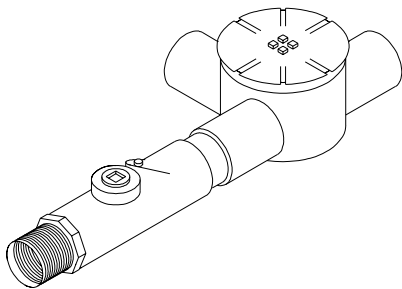

- 2 Thread the reducer bushing into the junction box. Then thread the male adapter into the reducer bushing. Finally, thread the seal fitting into the male adapter. Tighten to a minimum of 5 full threads of engagement.

Note: If the seal fitting is to be mounted in vertical position, mount with the slanted small hole plug upwards.

- 3 Remove the metal end cap, compression ring and sealing grommet from the cable entry seal and thread the cable entry seal into the seal fitting. Tighten to a minimum of 5 full threads of engagement.
- 4 Repeat steps 2-3 for all seal fittings included in kit.

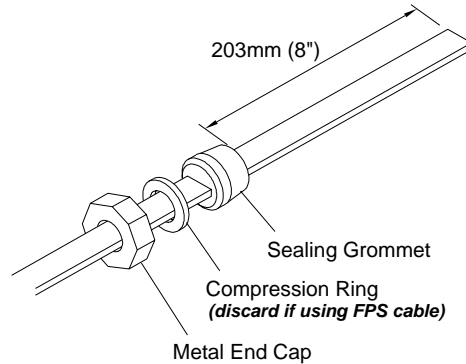

- 5 Slide a metal end cap, *compression ring and sealing grommet over each heater cable. Position each sealing grommet 203mm (8") from each cable end.

***FOR FPS HEATER CABLES ONLY:**

Discard the compression ring and only slide the metal cap and sealing grommet over the heater cable. Position the sealing grommet 203mm (8") from cable end.

Note: Each metal end cap, compression ring (if used) and sealing grommet must be oriented to fit correctly into each cable entry seal.

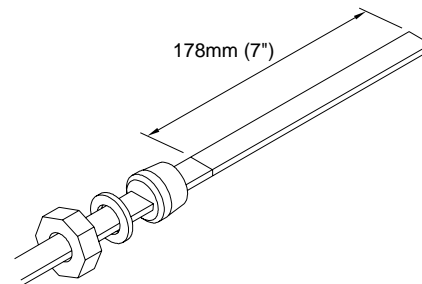

- 6 Prepare all heater cables for termination. Proceed to "Overjacket Stripping Procedures", sheet 3 of 8

OVERJACKET STRIPPING PROCEDURES

⚠ WARNING:
DO NOT CUT BRAID

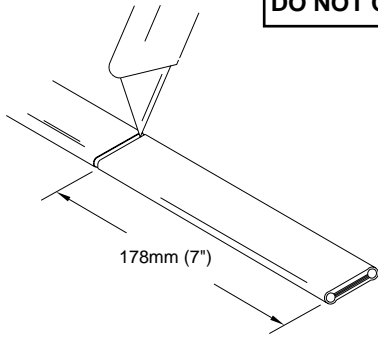

- 1 Lightly cut around heater overjacket 178mm (7") from the end. Bend cable to break overjacket.
- 2 Lightly cut overjacket up the center between first cut mark and the cable end. Bend cable to break overjacket.

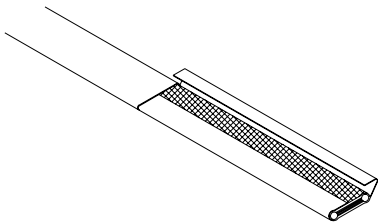

- 3 Remove overjacket from heater cable.

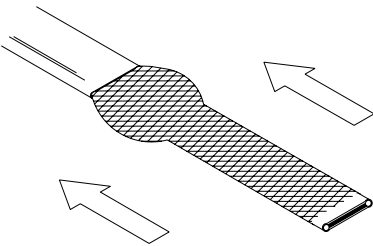

- 4 Move braid back toward the overjacket, creating a bulge.

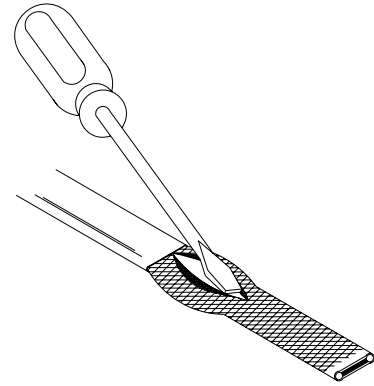

- 5 At the bulge, separate the braid to make an opening.

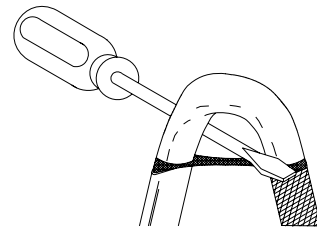

- 6 While bending the heater cable, work it through the braid opening.

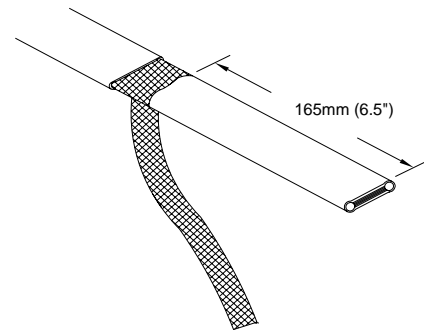

- 7 Pull the braid tight.
- 8 Proceed to "Outer Jacket Stripping Procedures", sheet 4 of 8.

SERGE BARIL HA-T HAZARDOUS AREA SEAL KIT

DIVISION 1 CABLE TEE SPLICE TERMINATION & EXPLOSION PROOF SEAL INSTRUCTIONS

OUTER JACKET STRIPPING PROCEDURES

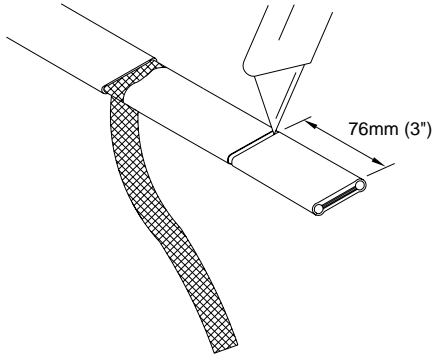

- 1 Lightly cut around heater outer jacket 76mm (3") from the end. Bend cable to break outer jacket.
- 2 Lightly cut the outer jacket up the center between the first cut mark & the cable end. Bend cable to break outer jacket.

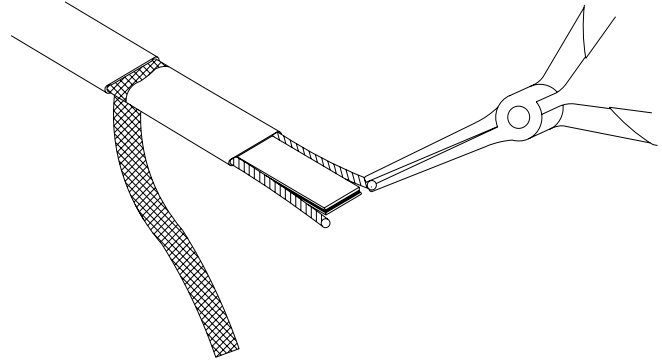

- 5 Starting at the end, pull each bus wire away from the core material.
- 6 Remove exposed core material.

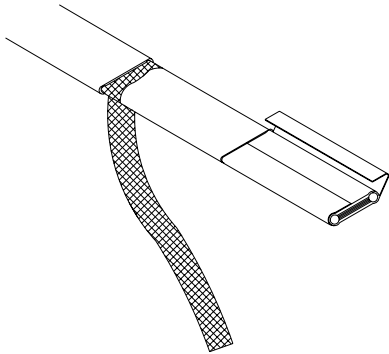

- 3 Remove the jacket from the heater cable.

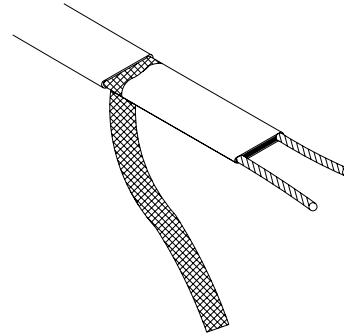

- 7 Cut 6mm (0.25") off the end of each bus wire.
- 8 Proceed to "Power Termination", sheet 5 of 8.

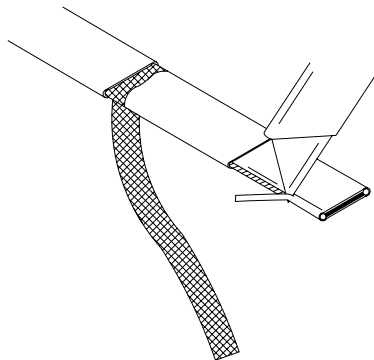

- 4 Shave the core material from the outside of each bus wire.

⚠ WARNING:
DO NOT CUT BUS WIRES

POWER TERMINATION

⚠ WARNING:

- Bus wires must not touch or cross while inserting into power termination.
- Only power terminations specifically approved for the vendors style and type of heater cable must be used.

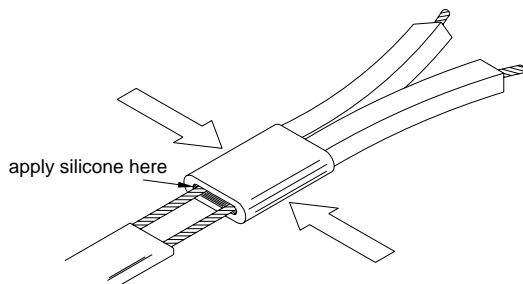

- 1 Insert bus wires into power termination.
- 2 Squeeze power termination opening and fill with silicone.

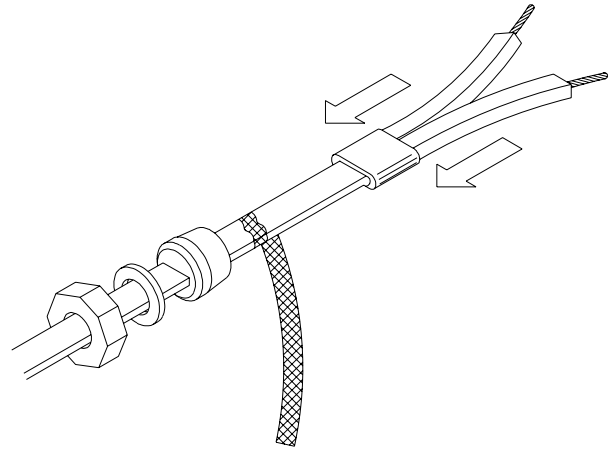

- 3 Push power termination to overlap jacket.
- 4 Proceed to "Seal Fitting Installation", sheet 6 of 8.

SERGE BARIL HA-T HAZARDOUS AREA SEAL KIT

DIVISION 1 CABLE TEE SPLICE TERMINATION & EXPLOSION PROOF SEAL INSTRUCTIONS

INSTALLATION INSTRUCTIONS

SEAL FITTING INSTALLATION

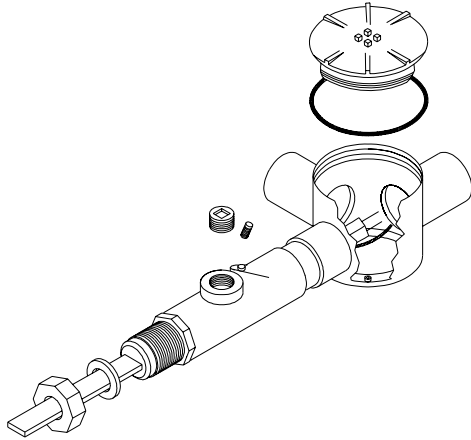

- 1 Remove box cover and box cover gasket from junction box, place a power termination through each cable entry seal and seal fitting. Slide forward until the sealing grommet is flush with the entry seal.

Note: The heater cable must be positioned in the seal fitting so the braid transition point is visible through the seal fitting opening. See Detail "A" on sheet 8 of 8 for example.

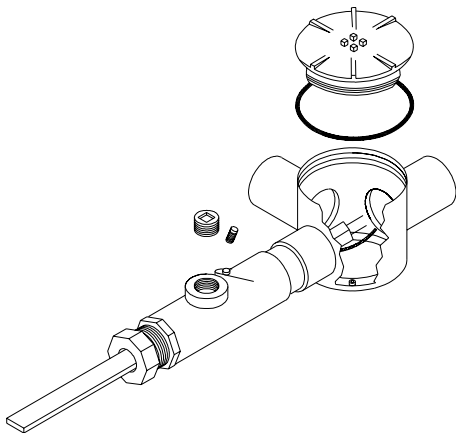

- 2 Slide the compression ring (if used) and the metal end cap forward and thread onto the cable entry seal. Tighten to 51 foot pounds.
- 3 Repeat steps 1-2 for all seal fittings included in kit.

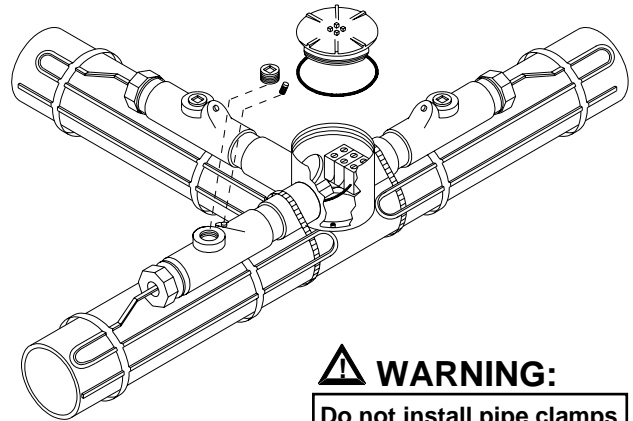

WARNING:

Do not install pipe clamps over the heater cables.

- 4 Mount the junction box to pipe using pipe clamps included.
- 5 Connect bus wires to the terminal block. Connect ground braid from all heater cables to green ground screw.
- 6 Place the box cover gasket and box cover onto the junction box.
- 7 Proceed to "Sealing Compound Procedure", sheet 7 of 8.

SEALING COMPOUND PROCEDURE

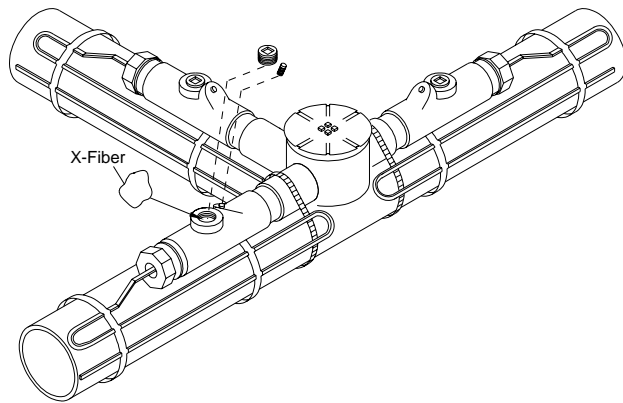

- 1 Center a heater cable inside each conduit opening. Using the X fiber, pack around each heater cable forming a dam to hold the sealing compound.

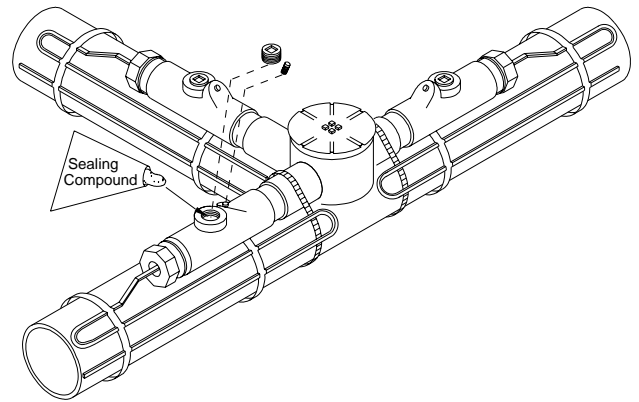

- 2 Mix the sealing compound according to instructions on the pouch, (**knead to mix liquid and powder in pouch**). Snip off a corner of the pouch and fill each seal.

SERGE BARIL HA-T HAZARDOUS AREA SEAL KIT

DIVISION 1 CABLE TEE SPLICE TERMINATION & EXPLOSION PROOF SEAL INSTRUCTIONS

TEMPLATE

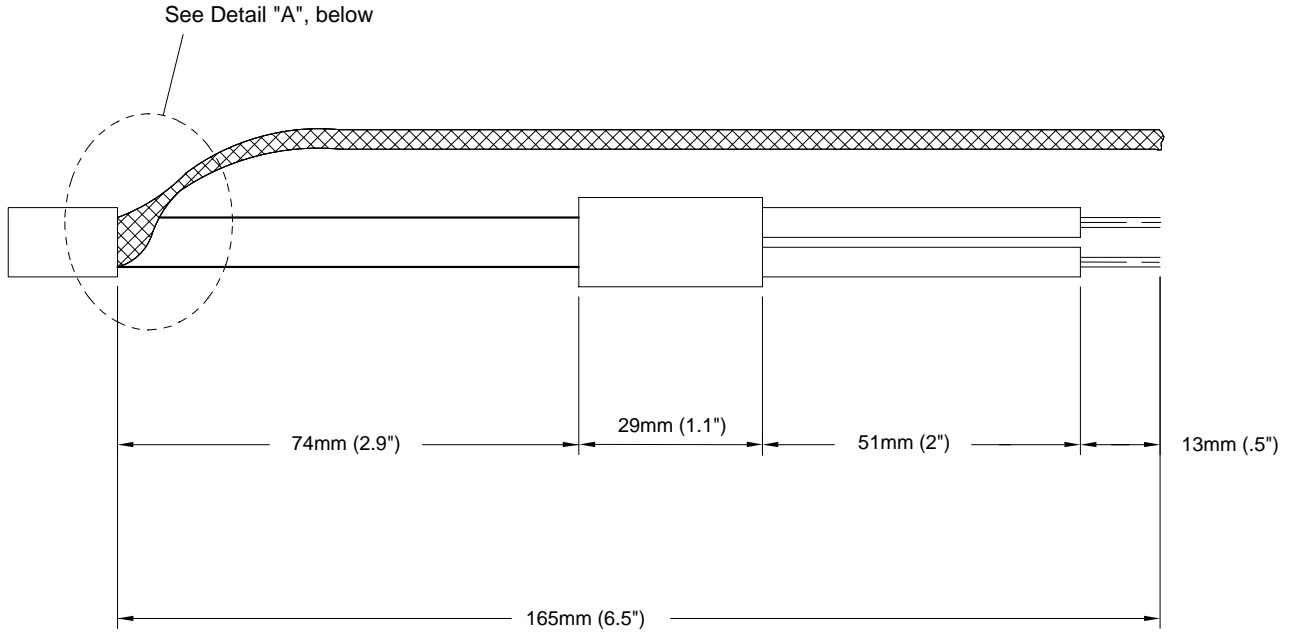

DETAIL "A"

