

SERGE BARIL HEAT TRACING SYSTEMS

HA-P HAZARDOUS AREA SEAL KIT FOR DIV. 1 CABLE TERMINATION & EXPLOSION PROOF SEAL

INSTALLATION INSTRUCTIONS

DESCRIPTION

The HA-P Hazardous Area Seal Kit provides the cable termination and explosion proof seal parts needed to make the power end electrical connections associated with Serge Baril Heat Tracing Systems' self-regulating heater cables.

KIT CONTENTS

- | | |
|--------------------|---------------------|
| 1 Junction Box | 1 Stand-off |
| 1 Tube of Silicone | 1 Power Termination |
| 1 Sealing Compound | 1 Terminal Block |
| 1 Sealing Grommet | 1 X Fiber |
| 1 Conduit Plug | 1 Seal Fitting |
| 2 Pipe Clamps | 1 Male Adapter |

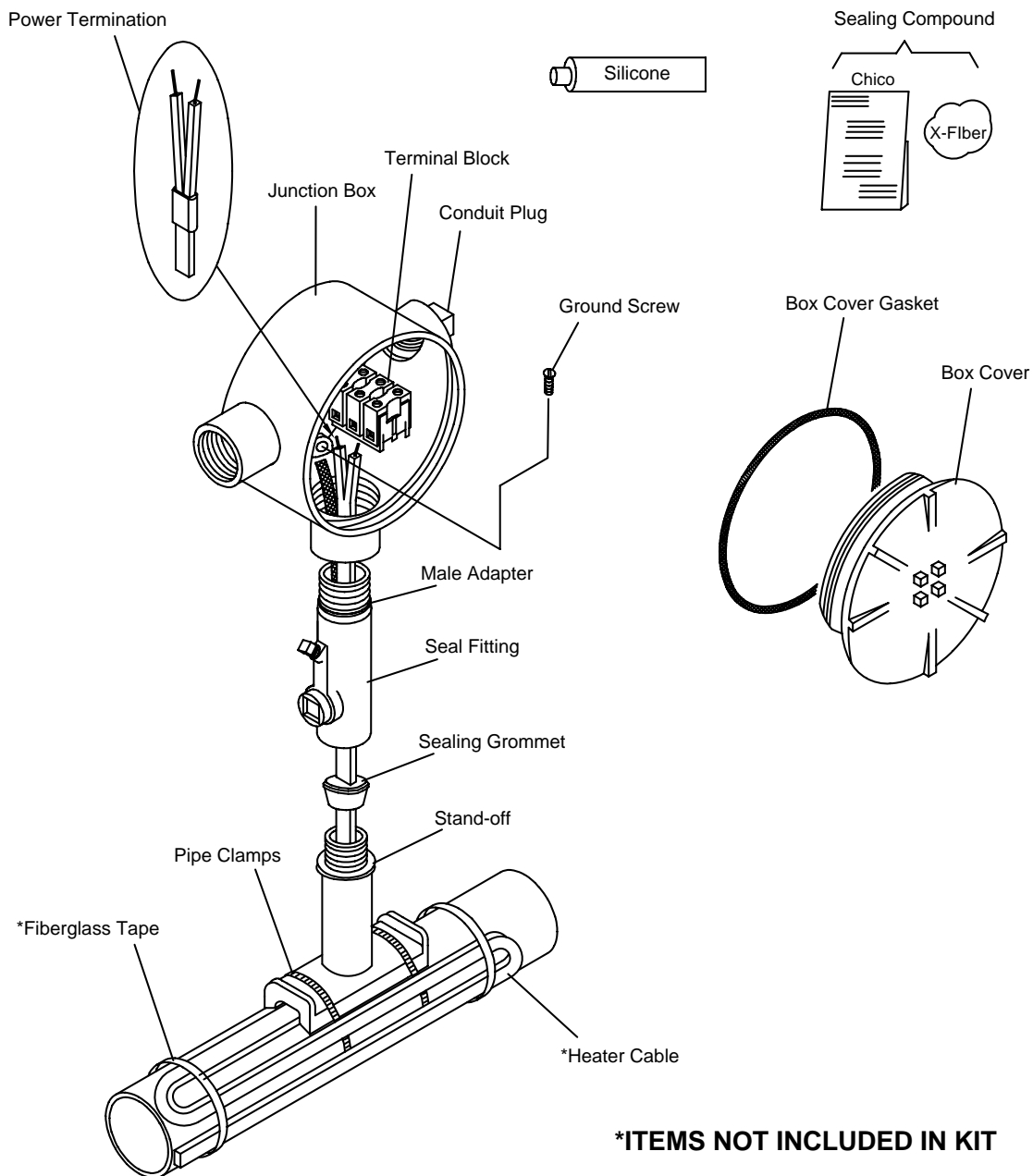

SERGE BARIL HEAT TRACING SYSTEMS

HA-P HAZARDOUS AREA SEAL KIT FOR DIV. 1 CABLE TERMINATION & EXPLOSION PROOF SEAL

INSTALLATION INSTRUCTIONS

STAND-OFF POSITIONING

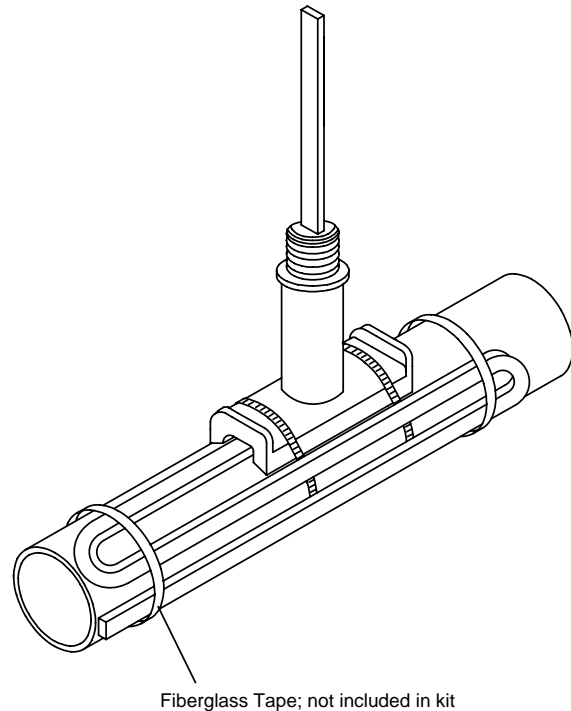
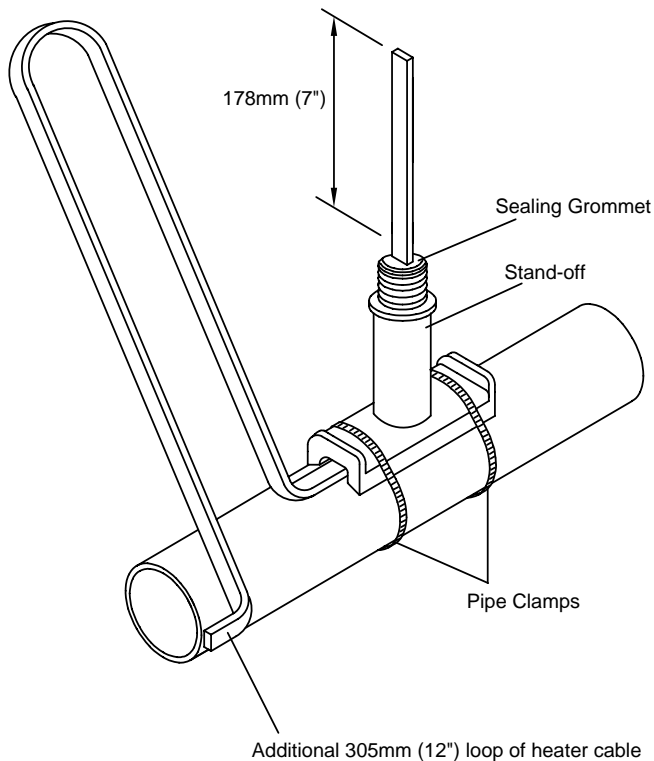

⚠ WARNING:

Do not install pipe clamps over the heater cable.

- 1 Push heater cable through the bottom opening of the stand-off. Allow 178mm (7'') of heater cable for termination. Leave a 305mm (12'') loop of additional cable to be installed after the stand-off is secured.
- 2 Mount stand-off to pipe using the pipe clamps included in kit.
- 3 Slide the sealing grommet over heater cable and position at stand-off.

- 4 Secure the additional 305mm (12'') of heater to the pipe using fiberglass tape (not included in kit).
- 5 Prepare heater cable for termination. Proceed to "Overjacket Stripping Procedures" on sheet 3.

SERGE BARIL HEAT TRACING SYSTEMS

HA-P HAZARDOUS AREA SEAL KIT FOR DIV. 1 CABLE TERMINATION & EXPLOSION PROOF SEAL

INSTALLATION INSTRUCTIONS

OVERJACKET STRIPPING PROCEDURES

⚠ WARNING:
DO NOT CUT BRAID

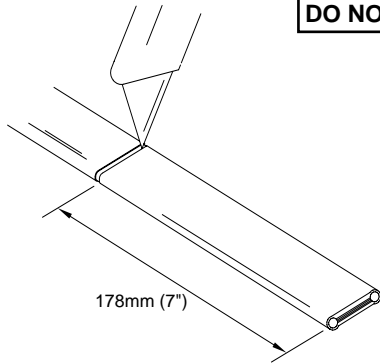

- 1 Lightly cut around heater overjacket 178mm (7") from the end. Bend cable to break overjacket.
- 2 Lightly cut overjacket up the center between first cut mark and the cable end. Bend cable to break overjacket.

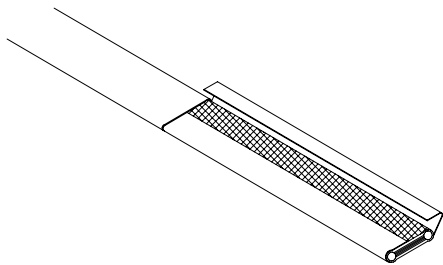

- 3 Remove overjacket from heater cable.

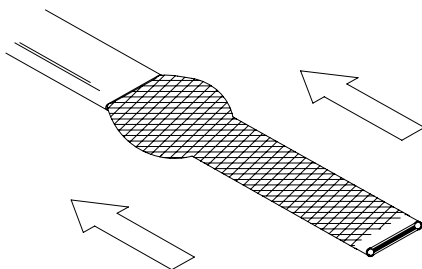

- 4 Move braid back toward the overjacket, creating a bulge.

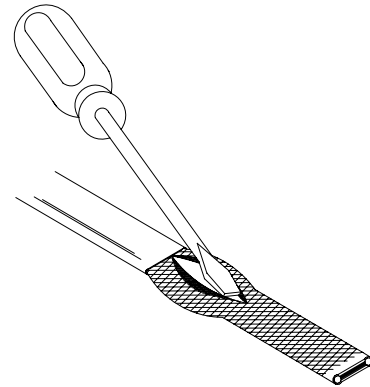

- 5 At the bulge, separate the braid to make an opening.

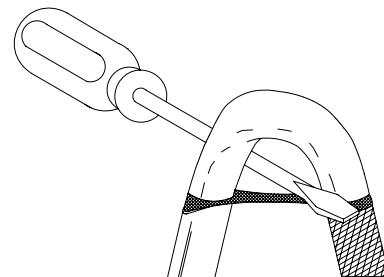

- 6 While bending the heater cable, work it through the braid opening.

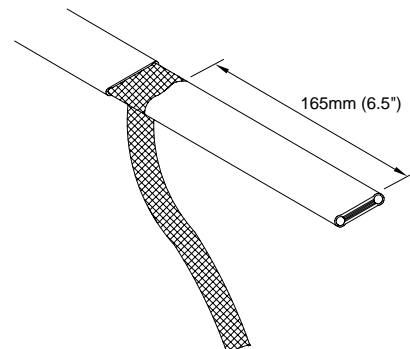

- 7 Pull the braid tight.
- 8 Proceed to "Outer Jacket Stripping Procedures" on sheet 4.

SERGE BARIL HEAT TRACING SYSTEMS

HA-P HAZARDOUS AREA SEAL KIT FOR DIV. 1 CABLE TERMINATION & EXPLOSION PROOF SEAL

INSTALLATION INSTRUCTIONS

OUTER JACKET STRIPPING PROCEDURES

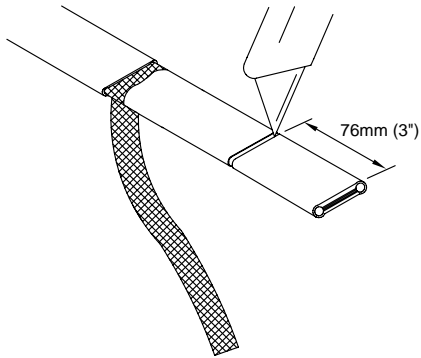

- 1 Lightly cut around heater outer jacket 76mm (3") from the end. Bend cable to break outer jacket.
- 2 Lightly cut the outer jacket up the center between the first cut mark & the cable end. Bend cable to break outer jacket.

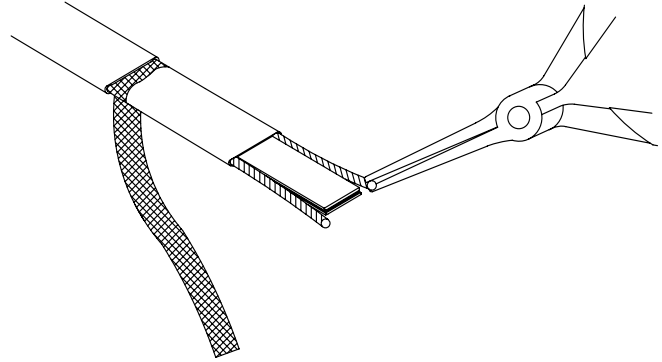

- 5 Starting at the end, pull each bus wire away from the core material.
- 6 Remove exposed core material.

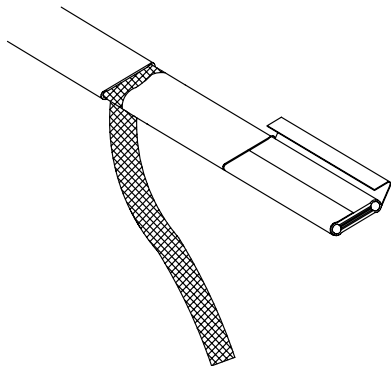

- 3 Remove the jacket from the heater cable.

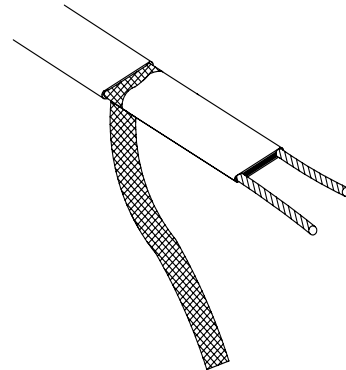

- 7 Cut 6mm (0.25") off the end of each bus wire.
- 8 Proceed to "Power Termination" on sheet 5.

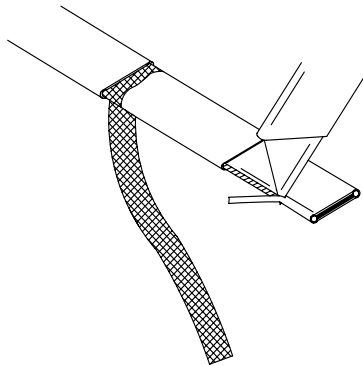

⚠ WARNING:
DO NOT CUT BUS WIRES

- 4 Shave the core material from the outside of each bus wire.

SERGE BARIL HEAT TRACING SYSTEMS

HA-P HAZARDOUS AREA SEAL KIT FOR DIV. 1 CABLE TERMINATION & EXPLOSION PROOF SEAL

INSTALLATION INSTRUCTIONS

POWER TERMINATION

WARNING:

- Bus wires must not touch or cross while inserting into power termination.
- Only power terminations specifically approved for the vendors style and type of heater cable must be used.

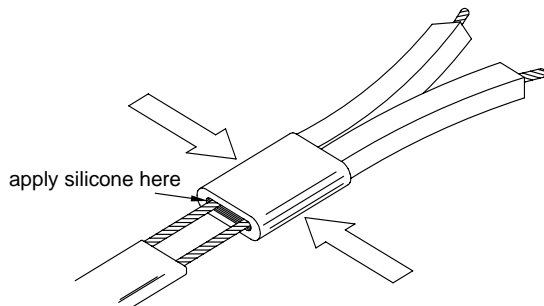

- 1 Insert bus wires into power termination.
- 2 Squeeze power termination opening and fill with silicone.

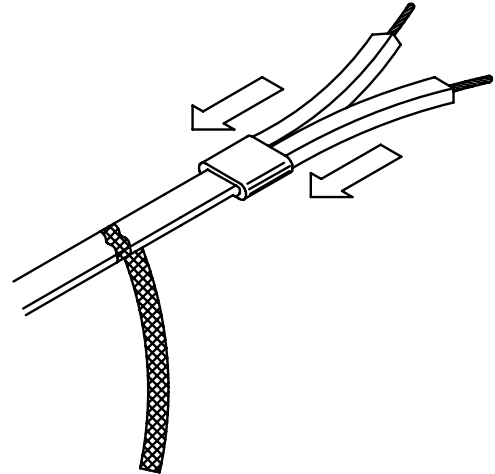

- 3 Push power termination to overlap jacket.
- 4 Proceed to "Seal Fitting Installation" on sheet 6.

SERGE BARIL HEAT TRACING SYSTEMS

HA-P HAZARDOUS AREA SEAL KIT FOR DIV. 1 CABLE TERMINATION & EXPLOSION PROOF SEAL

INSTALLATION INSTRUCTIONS

SEAL FITTING INSTALLATION

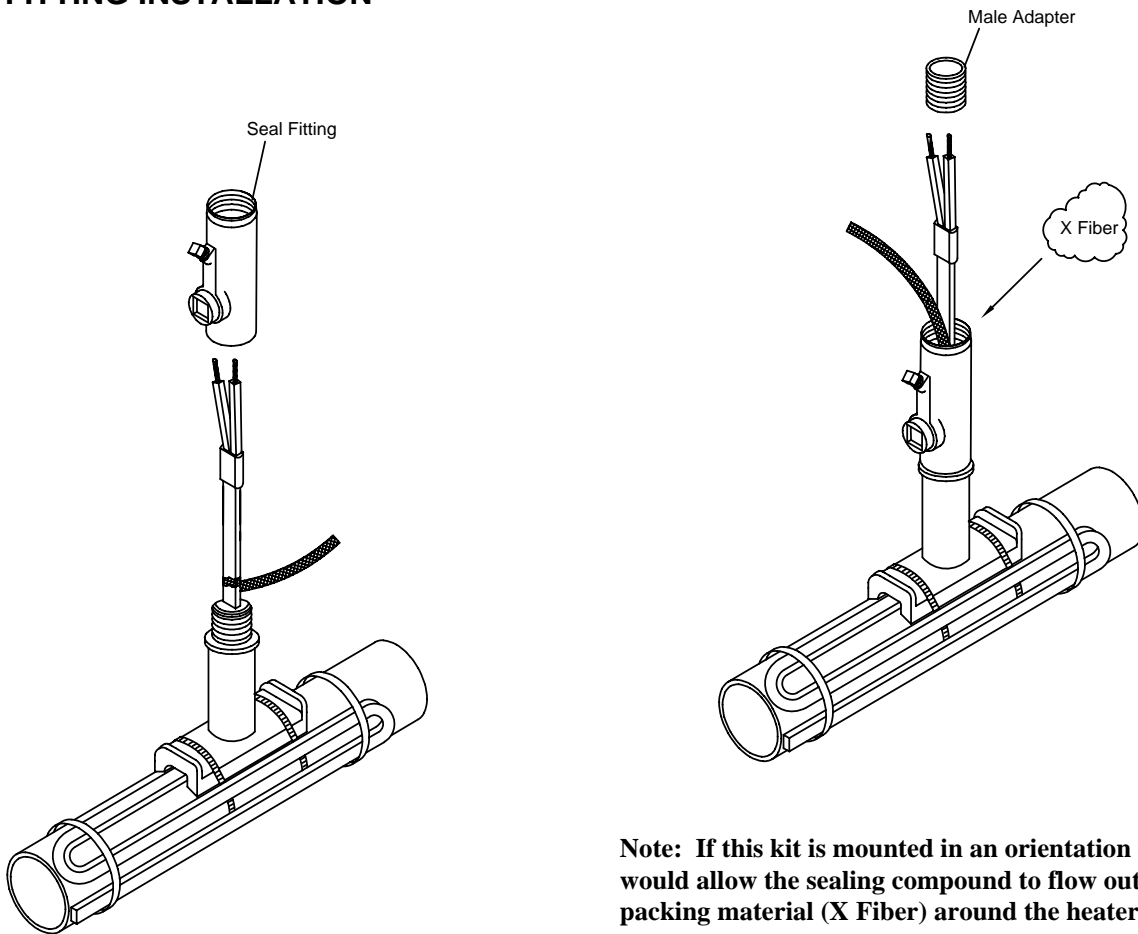

- 1 Slide seal fitting over the heater cable and braid, screw onto the stand-off by hand until snug fit.

Note: The heater cable must be positioned in the seal fitting so the braid transition point is visible through the seal fitting opening. See Detail "A" on sheet 8.

Note: If this kit is mounted in an orientation that would allow the sealing compound to flow out, place packing material (X Fiber) around the heater cable.

- 2 Slide male adapter over the heater cable and braid, screw into seal fitting by hand until snug fit.
- 3 Proceed to "Sealing Compound Procedure" on sheet 7.

SERGE BARIL HEAT TRACING SYSTEMS

HA-P HAZARDOUS AREA SEAL KIT FOR DIV. 1 CABLE TERMINATION & EXPLOSION PROOF SEAL

INSTALLATION INSTRUCTIONS

SEALING COMPOUND PROCEDURE

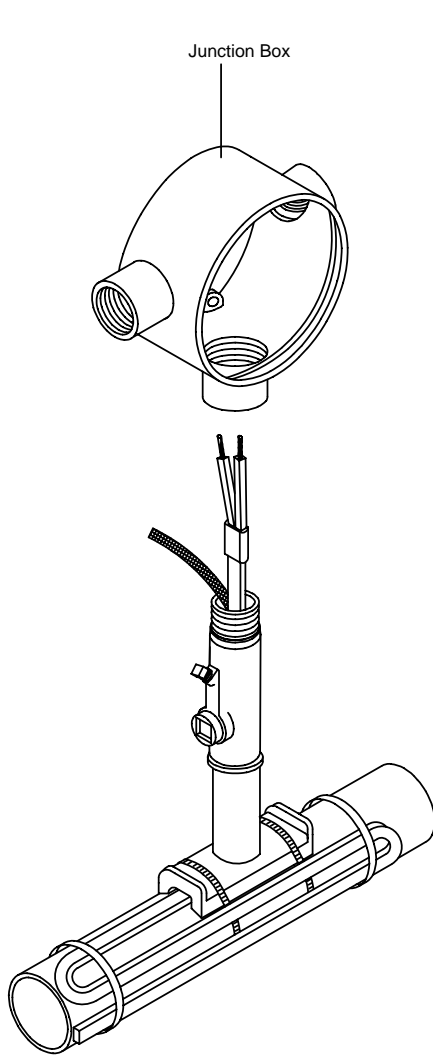

- 1 Place junction box over the heater cable and braid, screw onto male adapter until secure.

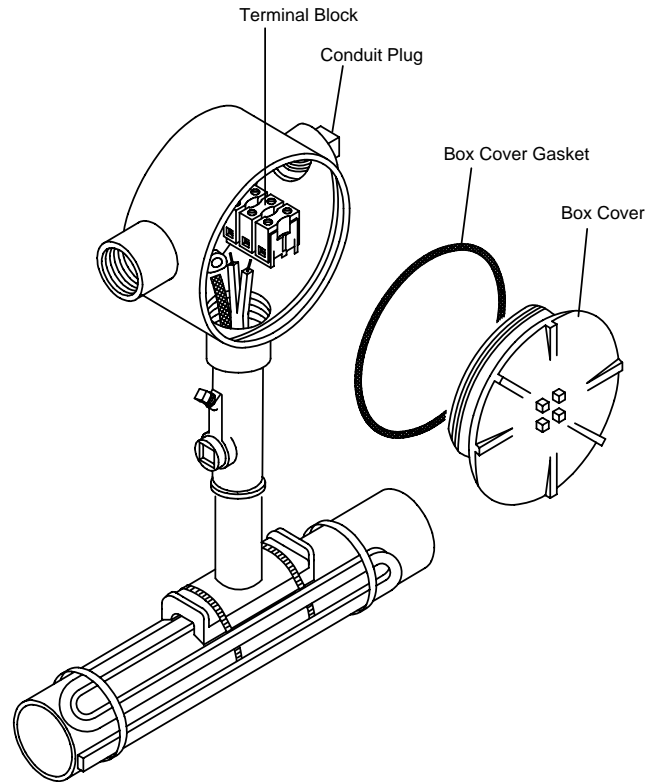

- 2 Connect bus wires to terminal block, one per terminal. Connect braid to green ground screw.
- 3 Place the box cover gasket and box cover onto junction box. Plug the unused conduit opening with the conduit plug.
- 4 Mix sealing compound according to the instructions on the pouch, (knead to mix liquid and powder in pouch). Snip off a corner of the pouch and fill the seal fitting.

⚠ WARNING:

Sealing compound must completely cover the braid transition point. See Detail "A" on sheet 8 for reference.

SERGE BARIL HEAT TRACING SYSTEMS

HA-P HAZARDOUS AREA SEAL KIT FOR DIV. 1 CABLE TERMINATION & EXPLOSION PROOF SEAL

INSTALLATION INSTRUCTIONS

TEMPLATE

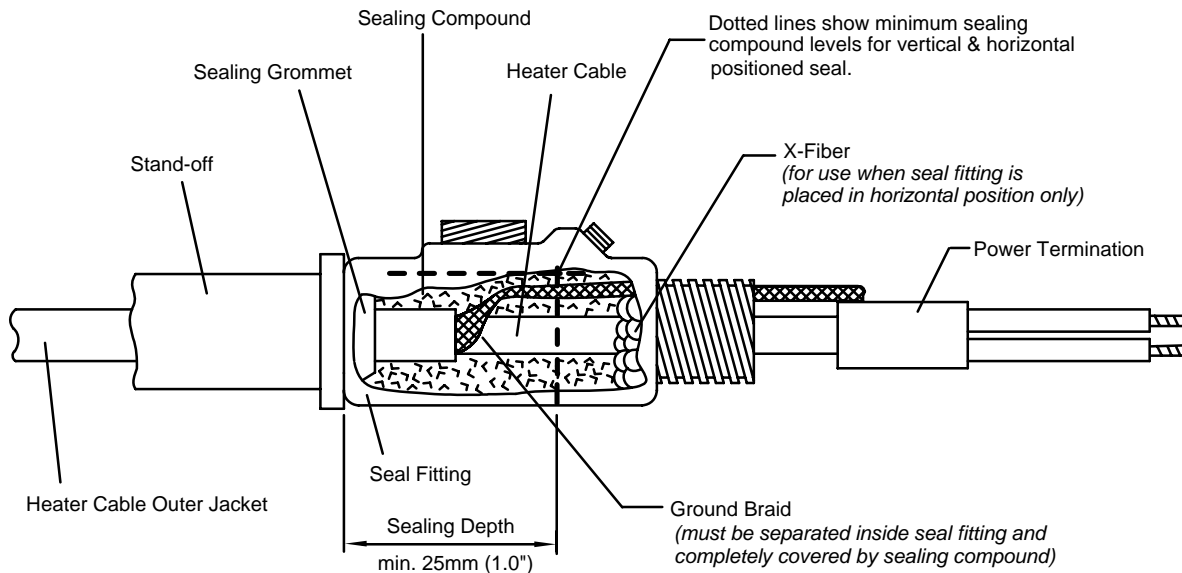
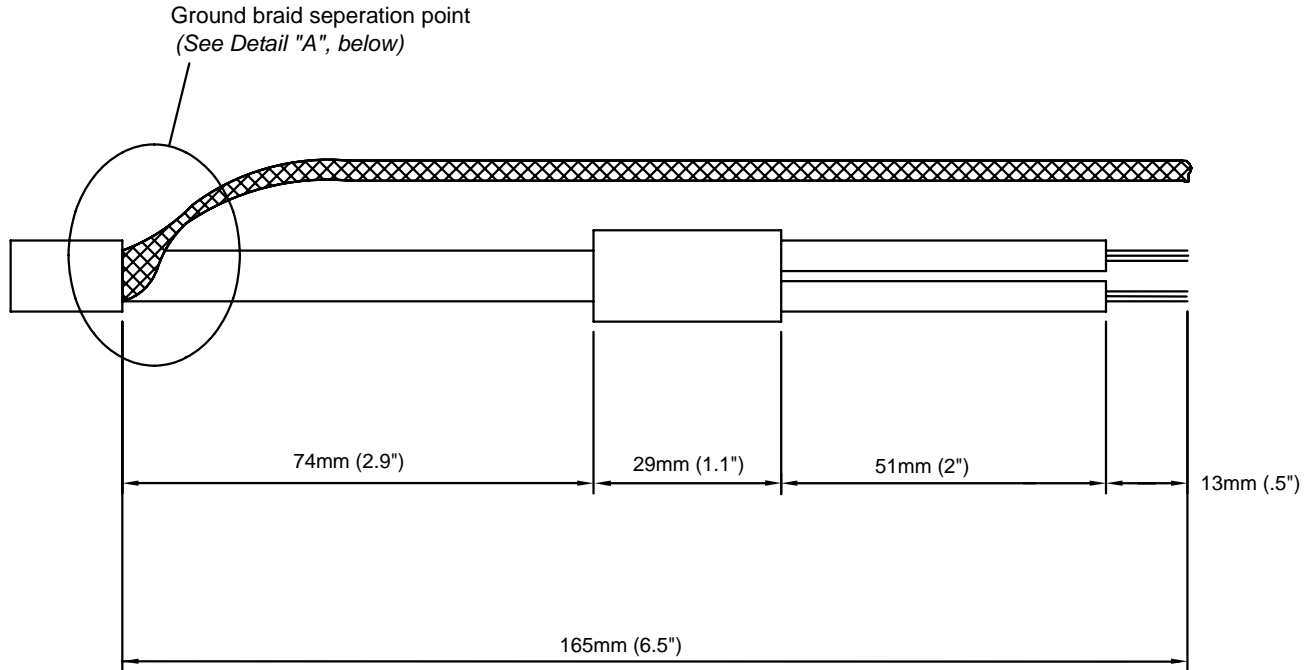

SERGE BARIL & ASS. INC.

5310 des Laurentides Blvd., Auteuil, Laval, Canada H7K 2J8

Tel.: (450) 622-7587 Fax: (450) 622-7869



GA-2386 Rev. 0
Sheet 8 of 8
November, 2003